

# ***Amana*** International Bottom Freezer Refrigerator Owner's Manual

Keep these instructions for future reference. Be sure this manual stays with refrigerator.

English .....	2
Dansk .....	15
Deutsch .....	28
Ελληνικά .....	41
Español .....	54
Français .....	67
Italiano .....	80
Nederlands .....	93
Norsk .....	106
Português .....	119
Suomi .....	132
Svenska .....	145

# Contents

Electrical Requirements .....	2
Installation Instructions .....	3
Model Identification .....	2
Cutout Dimensions .....	3
Installation Checklist .....	5
Controls	
Fresh Food and Deepfreeze® Controls .....	6
Setting Controls .....	6
Fresh Food Features	
Spillsaver™ Shelves .....	6
Deli Port™ .....	7
Drawers .....	7
Crisper Tote™ .....	7
Covered Storage Bucket .....	8
Dairy Centers .....	8
Door Buckets .....	8
Door Shelf .....	8
Adjustable Dividers .....	9
Tall Package Retainer .....	9
Deepfreeze® Features	
Deepfreeze® Shelf .....	9
Wire Basket .....	9
Wire Divider .....	9
Pivot Bin™ .....	9
Care and Cleaning	
General .....	10
Odor Removal .....	10
Adhesives .....	10
Door Gaskets .....	10
Condenser Coils .....	10
Glass Shelves .....	10
Light Bulbs .....	11
Energy Tips .....	11
Vacation Tips .....	11
Normal Operating Sounds .....	12
Before Calling For Service .....	13
Warranty .....	14

# Electrical Requirements



Recognize this symbol as a safety precaution.



## WARNING

Refrigerator is designed to operate on a separate 230 volt, 50 hertz., 10A circuit.

# Model Identification

Product information is on the serial plate, located on ceiling of Fresh Food section. Record the following information:

Model Number: \_\_\_\_\_

Manufacturing Number: \_\_\_\_\_

S/N or Serial Number: \_\_\_\_\_

Date of purchase: \_\_\_\_\_

Dealer's name and address: \_\_\_\_\_

**Keep a copy of sales receipt** for future reference.

Enjoy this new Amana® refrigerator.

# Cutout Dimensions

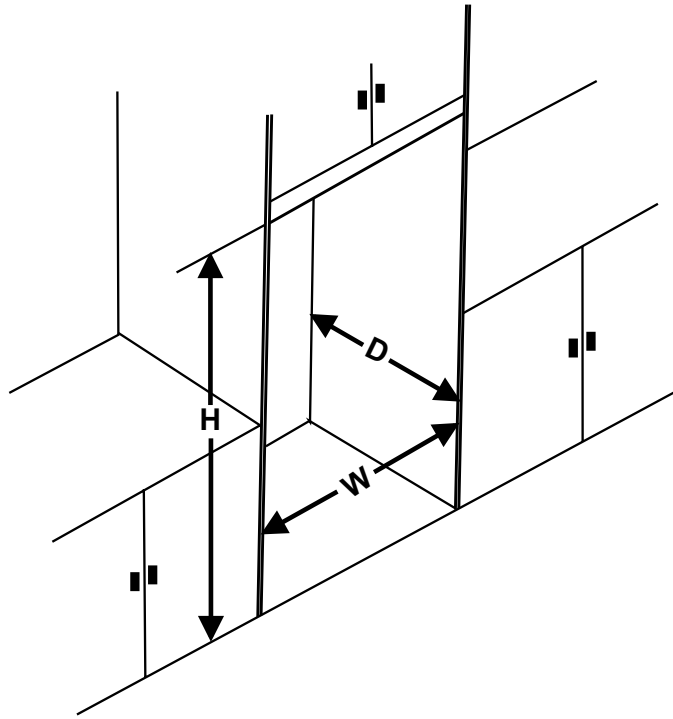

	Single Installation	Double Installation
H	175.3 cm with 30.5 cm deep cabinets above refrigerator. 177.8 cm with 61.0 cm deep cabinets above refrigerator.	
W	91.4 cm	184.8 cm
D	61.0 cm	61.0 cm

- See BID trim kit for specifications.

# Installation Instructions

## Introduction

A qualified engineer must connect refrigerator in accordance with these installation instructions. Measure door opening and depth and width of refrigerator. Remove handles or doors as required. Engineer must follow local electrical company connection regulations

Proper installation will ensure that this refrigerator operates most efficiently. Amana Refrigeration, Inc. cannot be responsible for improper installation.

- See HTK530 International Handle and Trim Kit for installation of door handles and trim.

## 1. Remove doors if necessary.

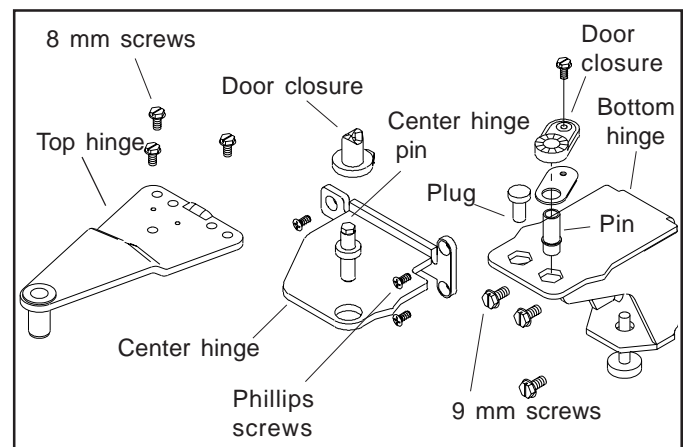

- Remove top hinge cover. Remove top hinge.
- Remove Fresh Food door.
- Lift door closure off center hinge pin. Remove center hinge pin.
- Remove Deepfreeze® door. An internal support rod may slide out. Replace rod prior to hanging door.
- Remove center hinge bracket.
- Remove toe grille. Remove bottom hinge(s).



### Caution

To avoid property damage, protect soft vinyl or other flooring with cardboard, rugs, or other protective material when moving refrigerator.

- Slide appliance cart under side of refrigerator. Wrap refrigerator with blanket or pad. Thread cart strap around refrigerator and tighten. Do not overtighten strap. Move refrigerator in front of final location.
- Reverse doors if necessary.
  - Replace internal support rod in hinge side of Deepfreeze® door prior to hanging door.
  - Move bottom hinge pin and door closure from right bottom hinge to left bottom hinge. Move plastic plug from left bottom hinge to right bottom hinge using a needle nose pliers. Pinch tabs from underside of hinge to remove.

- i. Rehang doors by reversing steps a-f.
- Space door 18 mm from cabinet.
  - Handle side of door should be approximately 3 mm higher than hinge side.

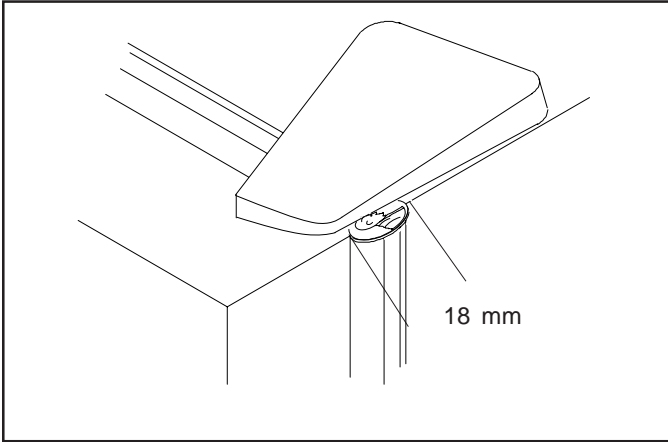

## 2. Plug in power cord.

- This equipment, including power cord, must be serviced only by qualified service personnel. Special tools are required to service equipment. Contact nearest authorized service facility for examination, repair or adjustment.

## 3. Move refrigerator into final location.

## 4. Level refrigerator.

- Remove toe grille.
- Turn roller adjustment screw to raise or lower rear of refrigerator.
- Turn stabilizing legs clockwise to raise or counterclockwise to lower front of refrigerator. Stabilizing legs must be firmly against floor.



### Caution

To avoid personal injury or property damage caused by refrigerator tipping, stabilizing legs must be firmly against floor.

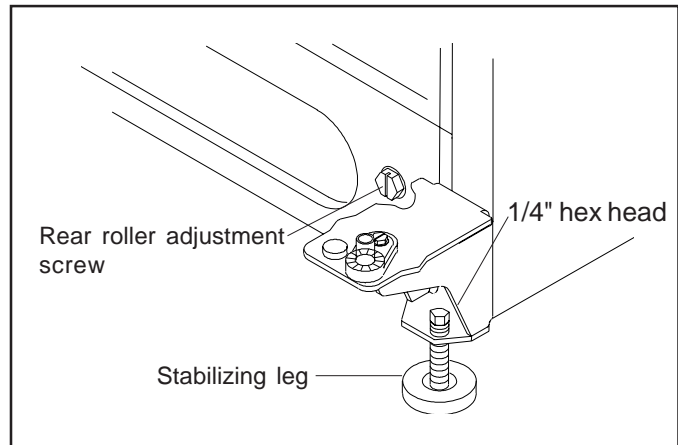

# Installation Checklist

---

This checklist is for personal records only.

Consumer	Installer	
----------	-----------	--

**Doors**

Handle side of door is 3 mm higher than hinge side of door. (Door lowers when loaded with food.)

Doors seal completely to refrigerator cabinet.

**Leveling**

Refrigerator is tilted 6 mm from front to rear.

Stabilizing legs are against floor.

Toe grille is properly attached to refrigerator.

**Product Literature**

Owner's manual is reviewed including the following information:

- Fresh Food and Deepfreeze® controls
- humidity controlled crisper drawer
- temperature controlled drawer
- normal operating sounds

Notes \_\_\_\_\_

\_\_\_\_\_

\_\_\_\_\_

\_\_\_\_\_

---

Consumer's Signature

---

Installer's Signature

---

Installer's Company Name/Phone Number

---

Date

## Controls

This refrigerator operates most efficiently in normal household temperatures of 13°C to 43°C.

### Fresh Food and Deepfreeze® Controls

Fresh Food control is located on upper rear wall of Fresh Food section.

Deepfreeze® control is located on right front ceiling of Deepfreeze® section.

When Deepfreeze® control is set "□", neither Fresh Food nor Deepfreeze® sections will cool. Initially, set both controls to 4. Wait 24 hours for Fresh Food and Deepfreeze® sections to reach desired temperatures. After 24 hours, adjust controls, one number at a time, as desired. 1 is warmest setting and 7 is coldest.

### Setting Controls

Set controls precisely using a household thermometer that includes temperatures between -21°C to 10°C.

Put thermometer snugly between frozen packages in Deepfreeze® section. Wait 5-8 hours. If Deepfreeze® temperature is not -17°C to -16°C, adjust control, one number at a time. Check again after 5-8 hours.

Put thermometer in a glass of water in middle of Fresh Food section. Wait 5-8 hours. If Fresh Food temperature is not 3°C to 4°C, adjust control, one number at a time. Check again after 5-8 hours.

## Fresh Food Features



### Caution

To avoid property damage, confirm shelf is secure before placing items on shelf.

### Spillsaver™ Shelves

Spillsaver™ shelves adjust to meet individual storage needs and hold simple spills for easier cleaning.



### Caution

To avoid personal injury or property damage, handle tempered glass shelves carefully. Shelves may break suddenly if nicked, scratched, or exposed to sudden temperature change.

- Remove shelves by lifting front, releasing hooks from metal track then pulling out.
- Replace shelves by inserting hooks into metal track and lowering front.

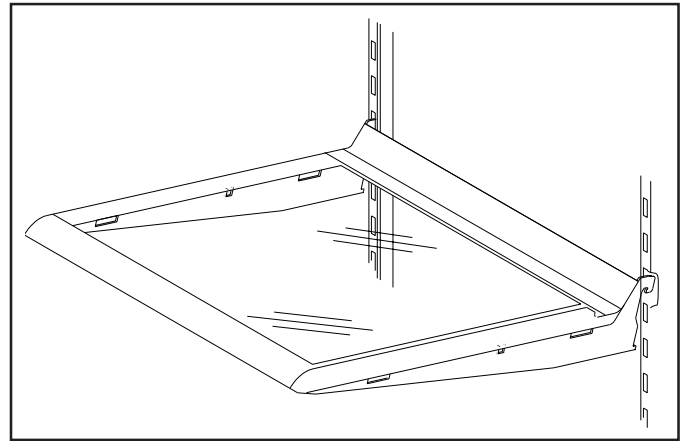

EasyGlide™ shelves pull forward for easy access of items in back.

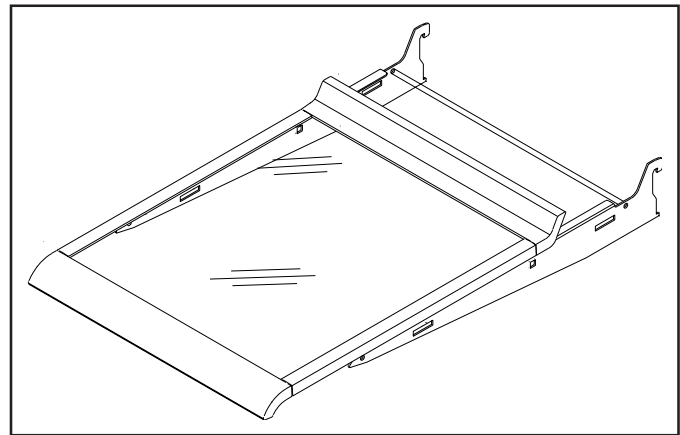

## Deli Port™

Deli Port™ provides space saving storage underneath Spillsaver™ shelf and pulls forward for easy access.

- Remove shelf by pulling forward until shelf stops. Push tabs on sides of shelf in and pull shelf forward.
- Replace shelf by inserting shelf into track and sliding back.

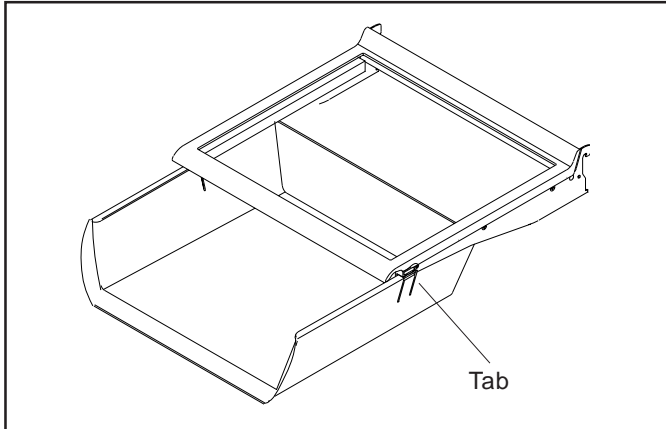

## Drawers

### Humidity Controlled Crisper Drawer

The right drawer is humidity controlled. This drawer keeps produce fresh longer. Wrap produce tightly. Do not wash produce before placing in drawer. Excess moisture could cause produce to spoil prematurely. Do not line drawer with paper towels. Paper towels will retain moisture.

Humidity control is located below front shelf trim. Control adjusts humidity in drawer. Slide control to right for produce with leaves such as lettuce, spinach or cabbage. Slide control to left for produce with skins such as cauliflower, corn or tomatoes.

### Temperature Controlled Drawer

The left drawer is temperature controlled. This drawer keeps food fresh longer and up to 3°C colder than Fresh Food temperature. Use this drawer for deli storage or additional produce storage.

Temperature control is located below front shelf trim. Control adjusts amount of air circulating around drawer. Slide control to left for normal Fresh Food temperature and to right for colder temperature. Ice crystals may form on drawer or food on coldest setting. Cold air can decrease Fresh Food temperature. Fresh Food control may need to be adjusted.

Remove shelf and drawers by completing the following steps.

1. Open left\* drawer. \*For doors hinged on left, open right drawer.



### Caution

To avoid personal injury or property damage, handle tempered glass shelves carefully. Shelves may break suddenly if nicked, scratched, or exposed to sudden temperature change.

2. Remove shelf by gently pushing up from underneath. Tilt one end up then pull out.
3. Remove left\* drawer by lifting front while supporting underneath then pulling out. \*For doors hinged on left, remove right drawer.
4. Remove support post at recess in bottom center of Fresh Food section by lifting.
5. Remove other crisper by sliding to opposite wall. Lift front while supporting underneath then pull out.
6. Replace drawers and shelf by reversing steps 1-5.

## Crisper Tote™

Crisper Tote™ provides easy access and protection for small produce such as cherry tomatoes, lemons, mushrooms, etc. in the humidity controlled crisper drawer.

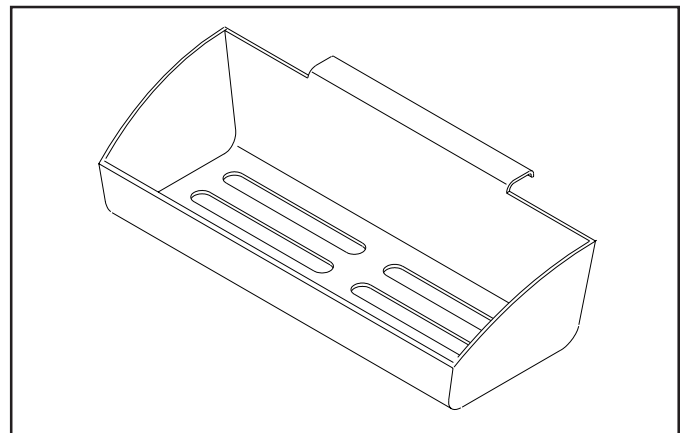

## Covered Storage Bucket

Storage bucket has a lid and removable egg tray. When tray is removed, bucket will accept items such as a standard egg carton, ice, etc.

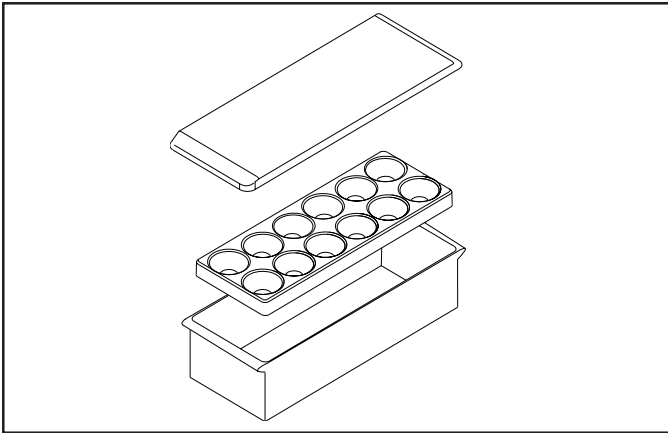

## Dairy Centers

Dairy centers provide convenient storage for items such as butter, cheese, etc.

- Remove dairy centers by lifting door, pushing tabs toward center and pulling out.
- Replace dairy centers by sliding in until tabs lock into place and lowering door.

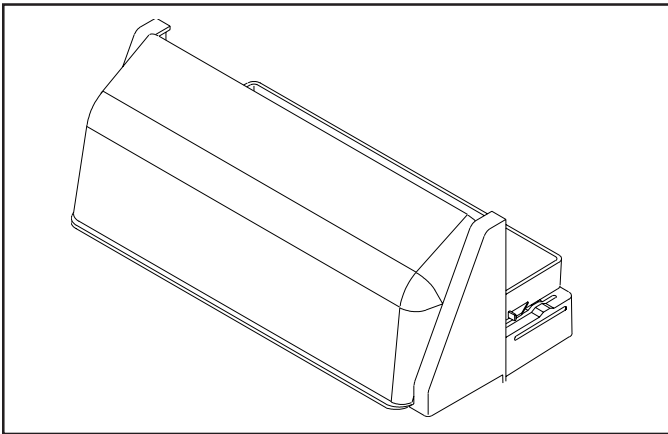

## Door Buckets

Door buckets adjust to meet individual storage needs.

- Remove door buckets by pushing tabs toward center and pulling out.
- Replace door buckets by sliding in until tabs lock into place.

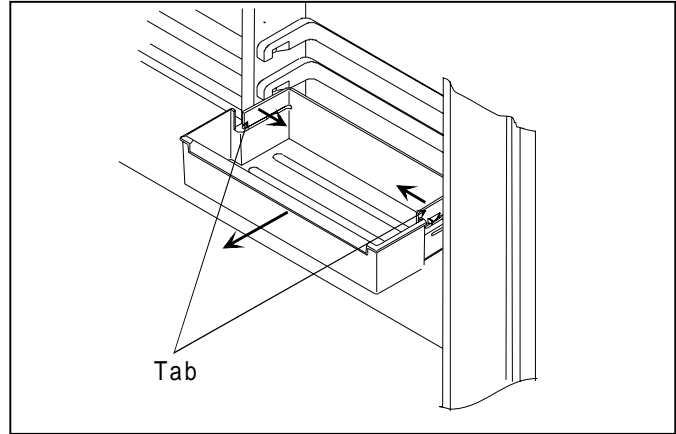

## Door Shelf

- Remove door shelf by lifting ends and pulling out.
- Replace door shelf by placing shelf on glides and sliding down.

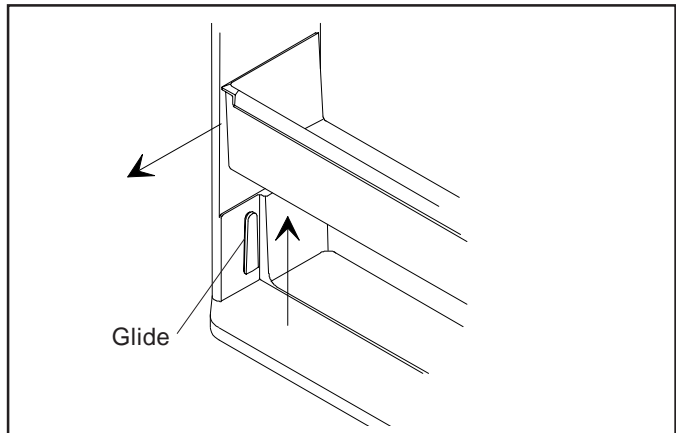

# Deepfreeze® Features

## Adjustable Dividers

Adjustable dividers keep items in place and adjust to meet individual storage needs. Divider fits in any Fresh Food door bucket or door shelf.

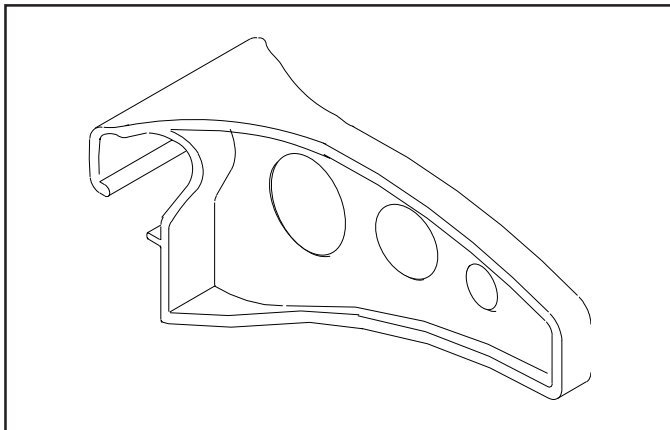

## Tall Package Retainer

Tall package retainer keeps tall items secure. Retainer fits in any Fresh Food door bucket or door shelf.

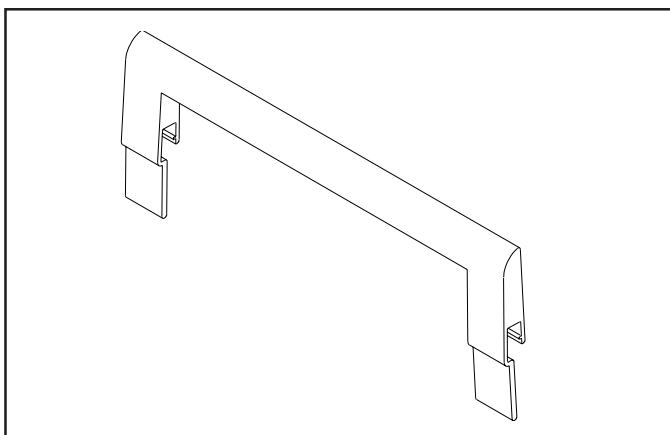

## Caution

To avoid property damage, confirm shelf is secure before placing items on shelf.

This refrigerator features an ice bucket, ice cube trays, ice service rack and slide out wire shelf.

- Remove ice service rack by lifting rack off plastic washers then pulling out.
- Replace ice service rack by placing rack on washer and sliding down until secure.

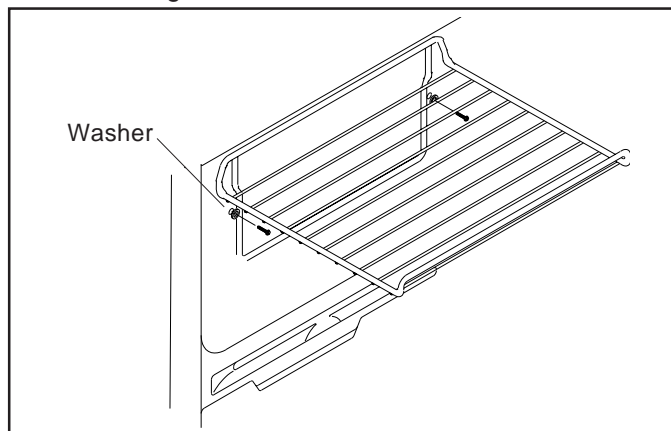

## Deepfreeze® Shelf

- Remove Deepfreeze® shelf by pulling out. A sharp tug may be necessary.
- Replace Deepfreeze® shelf by sliding in until back locks in place.

## Wire Basket

Wire basket slides out for easy access of items in back.

- Remove wire basket by lifting and pulling out.
- Replace wire basket by sliding in.

## Wire Divider

Wire divider organizes storage space. Divider can be moved left or right.

## Pivot Bin™

Pivot Bin™ provides convenient storage for frozen food items in Deepfreeze® door and tilts forward for easy access of those items.

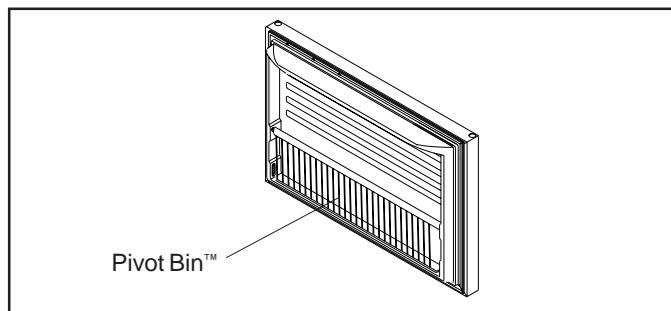

# Care and Cleaning

---



## WARNING

To avoid electrical shock which can cause severe personal injury or death, disconnect power to refrigerator before cleaning. After cleaning, connect power.



## Caution

To avoid personal injury or property damage, read and follow all cleaning product manufacturer's directions.

## General

1. Wash surfaces with 4 tablespoons baking soda dissolved in 1 liter warm water and a soft, clean cloth.
  2. Rinse surfaces with warm water. Dry surfaces with a soft, clean cloth.
- Do not use the following items:
    - abrasive or harsh cleaners, ammonia, chlorine bleach, etc.
    - concentrated detergents or solvents
    - metal scouring padsThese items can scratch, crack and discolor surfaces.
  - Do not place buckets, shelves, etc. in dishwasher.

## Odor Removal

1. Remove all food.
2. Clean all interior surfaces including ceiling, floor, and walls according to "General" instructions. Pay special attention to corners, crevices, and grooves. Include all drawers, shelves, and gaskets.
3. Wash and dry all bottles, containers and jars before returning food to refrigerator. Wrap foods in tightly sealed containers to prevent further odor. After 24 hours, check if odor was eliminated.

Complete the following steps if odor was not eliminated.

4. Complete steps 1-2.
5. Place garden fresh crispers on top shelf of Fresh Food section. Pack Fresh Food and Deepfreeze® sections including doors with crumpled sheets of black and white newspaper.
6. Place charcoal briquettes randomly throughout newspaper.
7. Close doors and let stand 24-48 hours.
8. Remove charcoal briquettes and newspapers.
9. Complete steps 2-3.

## Adhesives

1. Remove glue residue by rubbing toothpaste into adhesive with fingers until adhesive loosens.
2. Rinse surface with warm water. Dry surface with a soft, clean cloth.

## Door Gaskets

1. Clean door gaskets every 3 months according to "General" instructions.
2. Apply a light film of petroleum jelly to keep gaskets pliable.

## Condenser Coils

Clean condenser coil every 3 months to ensure maximum performance of refrigerator. Accumulated dust and lint may cause the following:

- reduced cooling performance
- increased energy usage
- premature part failure

1. Remove toe grille by holding ends and pulling forward.
2. Clean front surface of condenser coil with a vacuum cleaner hose nozzle.
3. Replace toe grille by inserting clips in holes and snapping in.

## Glass Shelves



## Caution

To avoid personal injury or property damage, handle tempered glass shelves carefully. Shelves may break suddenly if nicked, scratched, or exposed to sudden temperature change.

Remove shelf by lifting front, releasing hooks from metal track then pulling out. Place shelf on a towel. Allow shelf to adjust to room temperature before cleaning.

Clean crevices by completing the following steps:

1. Dilute mild detergent and brush solution into crevices using a plastic bristle brush. Let set for 5 minutes.
2. Spray warm water into crevices using faucet spray attachment.
3. Dry shelf thoroughly and replace shelf by inserting hooks into metal track and lowering front.

## Energy Tips

### Light Bulbs



#### WARNING

To avoid electrical shock which can cause severe personal injury or death, disconnect power to refrigerator before replacing light bulb. After replacing light bulb, connect power.



#### Caution

To avoid personal injury or property damage, observe the following:

- Allow light bulb to cool.
  - Wear gloves when replacing light bulb.
- Access light bulbs by removing 2 outside back screws. Back of light bulb cover drops down. Replace light bulbs with 25-watt appliance bulbs.
  - Replace light bulb cover by holding cover against ceiling. Insert and tighten screws.

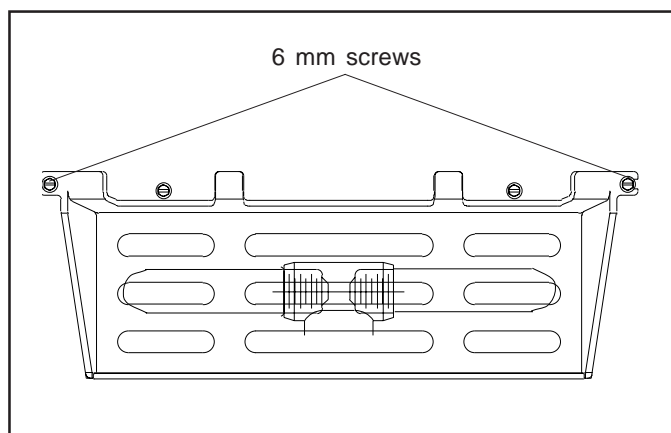

This refrigerator is designed to be one of the most energy efficient refrigerators available. Reduce energy use by observing the following.

- Operate in normal household temperatures of 13°C to 43°C away from heat sources and direct sunlight.
- Set Fresh Food, Deepfreeze®, and drawer controls no colder than necessary.
- Keep Deepfreeze® section full.
- Keep door gaskets clean and pliable. Replace gaskets if worn.
- Keep condenser coils clean.

### Vacation Tips

Complete the following steps for short vacations.

1. Remove perishable foods. **Warranty does not cover food loss.** Check warranty certificate for specific coverage.
2. If an ice maker is installed, move ice maker arm to off position.

Complete the following steps for long vacations.

1. Empty Fresh Food and Deepfreeze® sections.
2. Unplug refrigerator.
3. Clean refrigerator and door gaskets according to “General” instructions in “Care and Cleaning” section.
4. Prop doors open, so air can circulate inside.
5. If an ice maker is installed, turn water supply to refrigerator off and move ice maker arm to off position.

# Normal Operating Sounds

---

This new refrigerator may be replacing a differently designed, less efficient or smaller refrigerator. Today's refrigerators have new features and are more energy efficient. As a result, certain sounds may be unfamiliar. These sounds are normal and will soon become familiar. These sounds also indicate refrigerator is operating and performing as designed.

- **Deepfreeze® control** clicks when starting or stopping compressor.
- **Deepfreeze® fan** air rushes and whirs.
- **Sealed system** (evaporator and heat exchanger) refrigerant flow gurgles, pops or sounds like boiling water.
- **Defrost heater** sizzles, hisses or pops.
- **Condenser fan** air rushes and whirs.
- **Compressor** has a high pitched hum or pulsating sound.
- **Ice cubes** from ice maker (some models) drop into ice bucket.
- **Ice maker water valve hookup** (some models) buzzes when ice maker fills with water. This occurs whether or not refrigerator is connected to water supply. If refrigerator is not connected to water supply, stop sound by raising ice maker arm to off position.
- Foam insulation is very energy efficient and has excellent insulating capabilities. However, foam insulation is not as sound absorbent as previously used fiberglass insulation.

# Before Calling For Service

---

Refrigerator does not operate.

- Confirm Deepfreeze® control is on.
- Confirm refrigerator is plugged in.
- Check fuse or circuit breaker. Plug in another item at that wall outlet.
- Wait 40 minutes to see if refrigerator restarts. If Deepfreeze® control is on, lights work but 2 fans and compressor are not operating, refrigerator may be in defrost cycle.

Refrigerator still won't operate.

- Unplug refrigerator. Transfer food to another unit or place dry ice in Deepfreeze® section to preserve food. **Warranty does not cover food loss.** Check warranty certificate for specific coverage.

Food temperature appears too warm.

- See above sections.
- Allow time for recently added warm food to reach Fresh Food or Deepfreeze® temperature.
- Check gaskets for proper seal.
- Clean condenser coils.
- Adjust Fresh Food and/or Deepfreeze® control.

Temperature controlled drawer temperature is too warm.

- Slide control to colder setting.
- Adjust Deepfreeze® control to colder setting.

Food temperature is too cold.

- Clean condenser coils.
- Adjust Fresh Food control.
- Adjust Deepfreeze® control to warmer setting. Allow several hours for temperature to adjust.

Refrigerator runs too frequently.

- It may be normal to maintain constant temperature.
- Doors may have been opened frequently or for an extended period of time.
- Allow time for recently added warm food to reach Fresh Food or Deepfreeze® temperature.
- Clean condenser coils.
- Adjust Deepfreeze® control.
- Check gaskets for proper seal.

Water droplets form on inside of refrigerator.

- It is normal during high humidity periods or if doors have been opened frequently.

Water droplets form on outside of refrigerator.

- Check door gaskets for proper seal.

Drawers do not close freely.

- Check for a package which may prevent drawer from closing properly.
- Confirm drawer is in proper position.
- Clean drawer channels with warm, soapy water. Rinse and dry thoroughly.
- Apply a thin layer of petroleum jelly to drawer channels.
- Confirm refrigerator is level.

Refrigerator has an odor.

- See "Odor Removal" instructions in "Care and Cleaning" section.

# Warranty

## Limited One Year Warranty Limited Five Year Warranty on Compressor

### First Year

Raytheon Appliances will provide a free replacement part, f.o.b. Amana, Iowa, U.S.A., for any part which is defective due to workmanship or materials.

### Second through Fifth Years

Raytheon Appliances will provide a free replacement part, f.o.b. Amana, Iowa, U.S.A., for any compressor which is defective due to workmanship or materials.

### Warranty Limitations

- Begins at date of original purchase.
- Service must be performed by an **authorized** Amana technician.

### Warranty Is Void If

- Serial plate is defaced.
- Product is used on a commercial, rental or leased basis.
- Product has defect or damage due to product accident, alteration, connection to an improper electrical supply, fire, flood, lightning, shipping and handling, or other conditions beyond the control of Amana.
- Product is improperly installed or used.

### Owner's Responsibilities

- Provide proof of purchase (sales receipt).
- Provide normal care and maintenance. Replace owner replaceable items where directions appear in Owner's Manual.
- Make product reasonably accessible for service.
- Pay premium service costs for service outside technician's normal business hours.
- Pay for service calls related to product installation or usage.

**In no event shall Raytheon Appliances be liable for incidental or consequential damages including food loss\*.**

Any questions regarding the above or to locate an authorized servicer, contact appliance supplier or:

International Division  
Raytheon Appliances  
2800 220th Trail  
PO Box 8901  
Amana, IA 52204-0001  
USA  
Telephone 1-319-622-5511  
Facsimilie 1-319-622-2180